

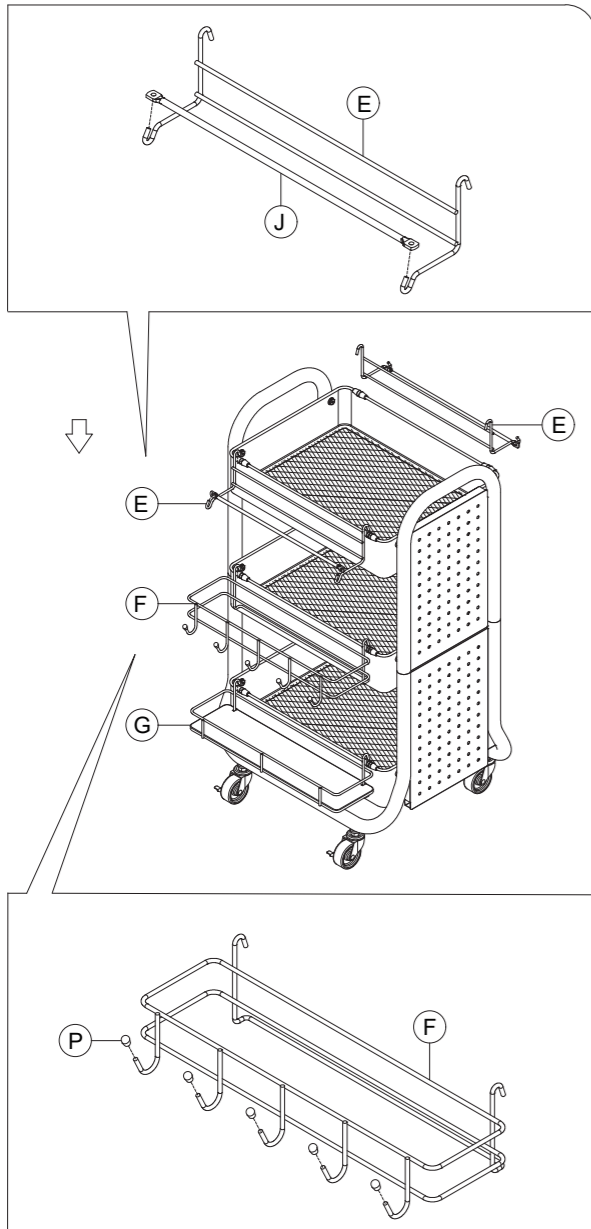

Maximum 20 lb (9 kg) load limit per tray.
Charge maximale de 9 kg (20 lb) par plateau.

7



8

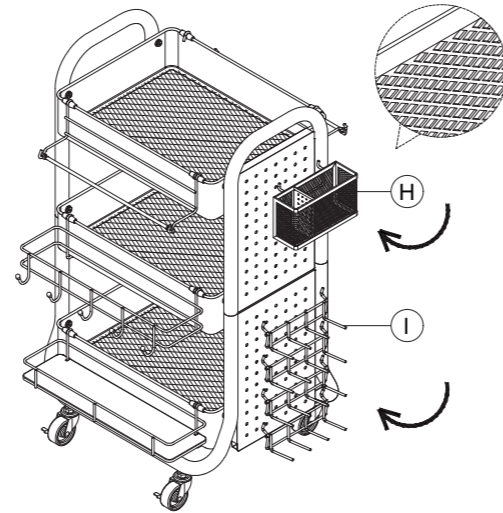

9

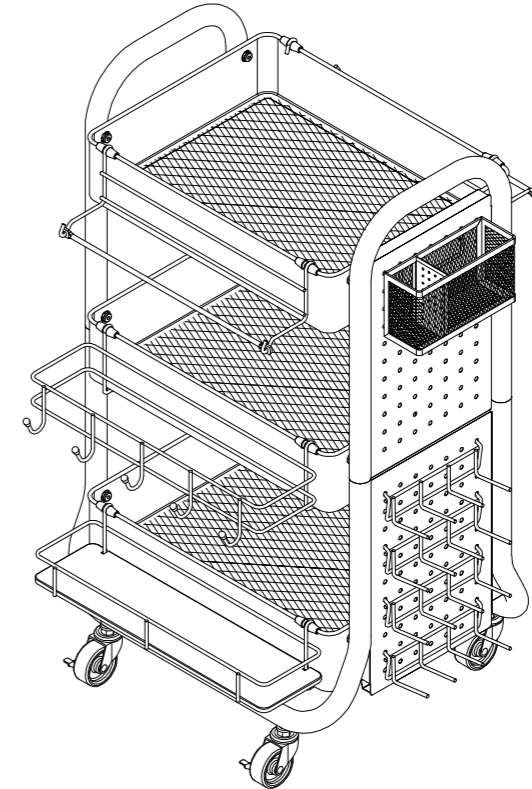
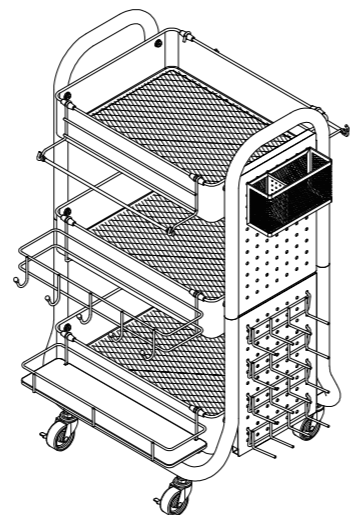

Warning

- ▲ Assemble on a soft level surface to avoid damaging the unit or your floor. Dispose of all packaging carefully and responsibly.
- ▲ To prevent the cart from being top-heavy and tipping over, place heavier items in bottom trays. Set cart on a level surface only.

Avertissement

- ▲ Afin d'éviter que le chariot soit trop chargé en haut et bascule, placer les articles plus lourds dans les plateaux du bas. Placer le chariot sur une surface plane seulement.
- ▲ Assembler le produit sur une surface douce à niveau pour éviter d'endommager l'unité ou le plancher. Jeter tous les emballages soigneusement et de façon responsable.

Care and Maintenance

- Use a dry cloth to clean the product, furniture polish is not recommended.
- From time to time check that there are no loose screws, nuts or bolts. If there are please re-tighten.

Entretien

- Utiliser un linge sec pour nettoyer le produit. Il est déconseillé d'utiliser de la cire pour meubles.
- De temps en temps, vérifier si toutes les vis, tous les boulons et écrous sont bien serrés. Si certains sont desserrés, veuillez les resserrer.

MADE IN CHINA / FABRIQUÉ EN CHINE

Call 1-800-642-4235 or /Email: customercare@michaels.com

Composez le 1-800-642-4235 ou envoyez un courriel à customercare@michaels.com

Full Parts List / Liste complète des pièces

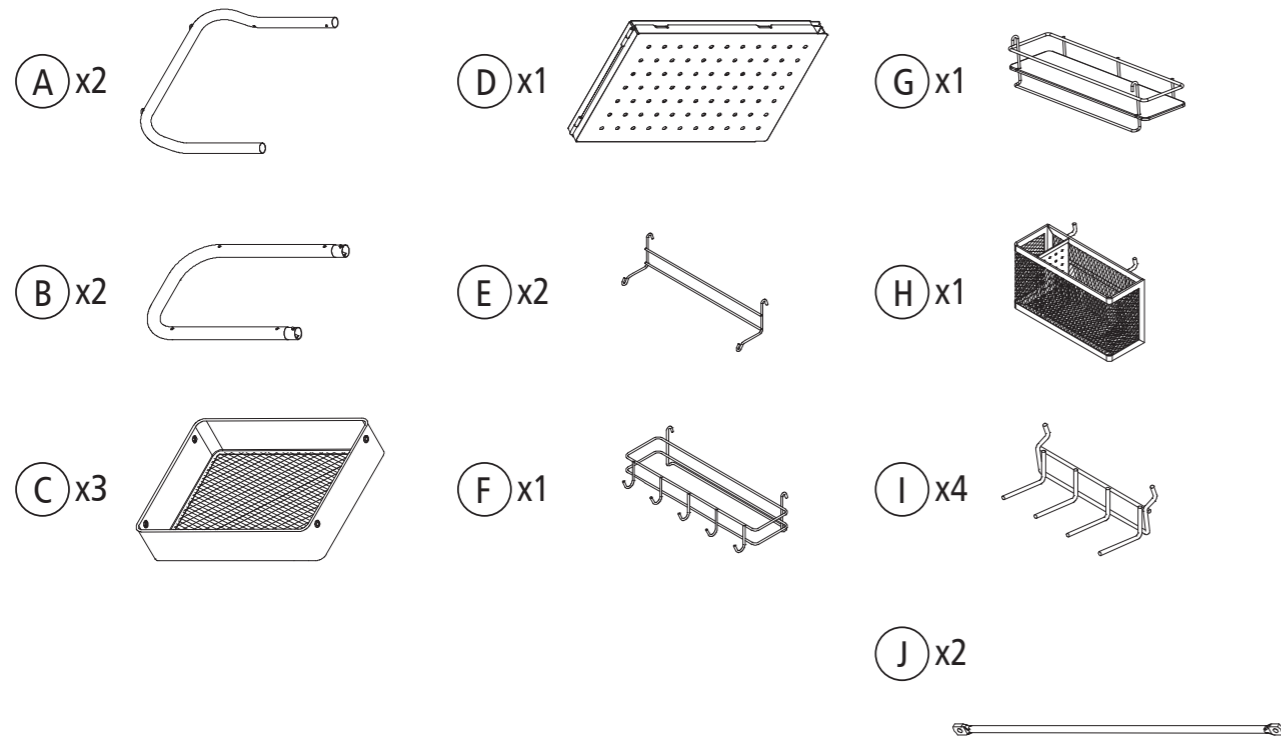

Assembly / Assemblage

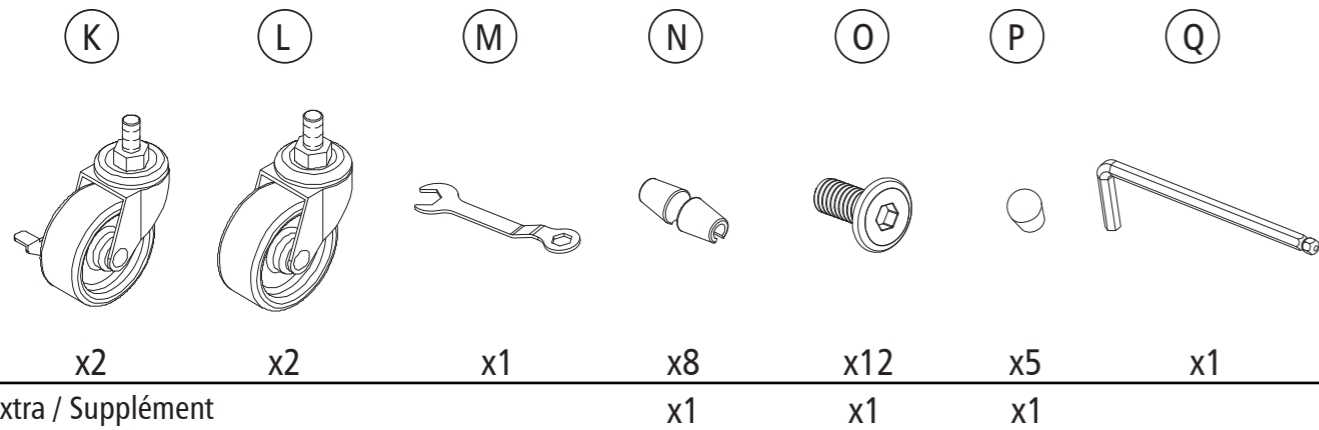

1

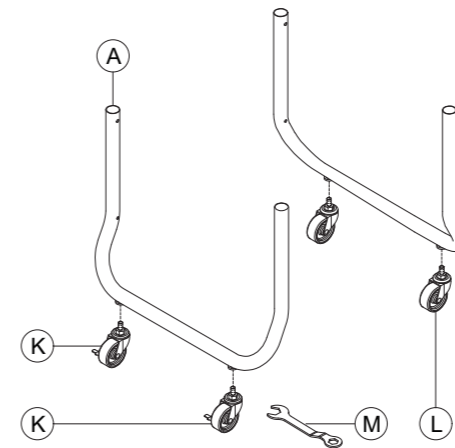

2

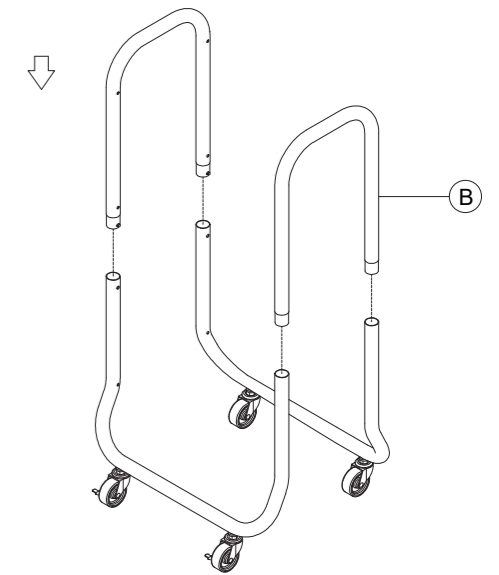

3

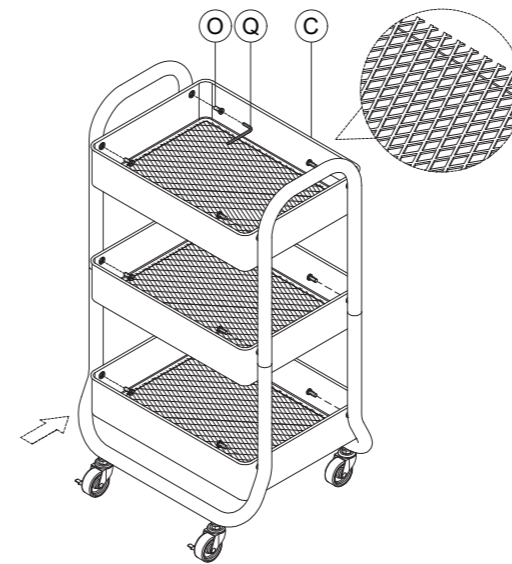

4

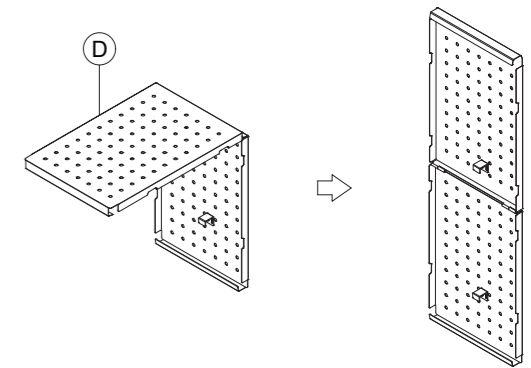

5

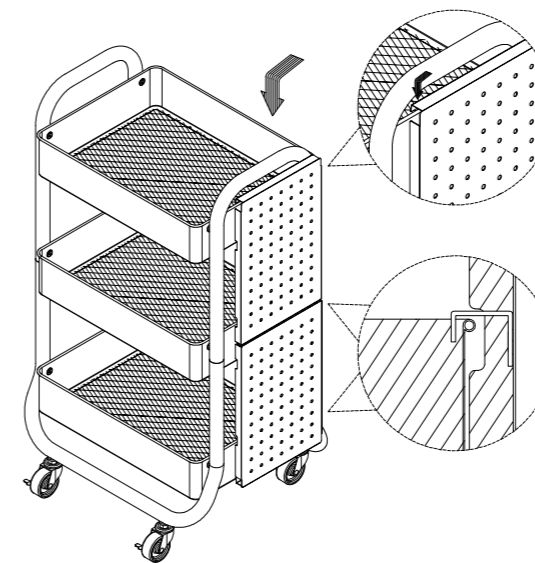

6

